

CODICE · ITEM NO. ARTIKEL NR. · RÉFÉRENCE	DESCRIZIONE · DESCRIPTION EZEICHUNG · DESCRIPTION	PAGINA · PAGE SEITE · PAGE	
NC-SD	YMW NORM 90°-125° Co8%	261	
NC-SD-TC	YMW NORM 90°-125° Co8% TiCN	261	
0021	A - DIN333 HSS	262	
0023	R - DIN333 HSS	262	
CD-S	A - YMW NORM 60° HSS	263	
CD-S-LH	A - YMW NORM LH 60° HSS	263	
CD-Q	A - YMW NORM 90° HSS	263	
CD-SL	A - YMW NORM L 60° HSS	264	
CD-SXL	A - YMW NORM XL 60° HSS	264	
C-CD-S	A - YMW NORM 60° CARBIDE	265	
CE-S	A - YMW NORM 60° HSS	266	
CE-S-TI	A - YMW NORM 60° HSS TiN	266	
CE-SL	A - YMW NORM L 60° HSS	267	
CE-SL-TI	A - YMW NORM L 60° HSS TiN	267	
CE-SXL	A - YMW NORM XL 60° HSS	267	
CE-SXL-TI	A - YMW NORM XL 60° HSS TiN	267	
CE-Q	A - YMW NORM 90° HSS	268	
CE-Q-TI	A - YMW NORM 90° HSS TiN	268	
CE-QL	A - YMW NORM L 90° HSS	269	
CE-QL-TI	A - YMW NORM L 90° HSS TiN	269	
CE-QXL	A - YMW NORM XL 90° HSS	269	
CE-QXL-TI	A - YMW NORM XL 90° HSS TiN	269	

🇮🇹 PUNTE A CENTRARE PER MACCHINE NC

🇬🇧 NC STARTING DRILLS

🇩🇪 NC ANBOHRER

🇫🇷 FORETS À CENTRER NC

90°, 125°

YMW NORM

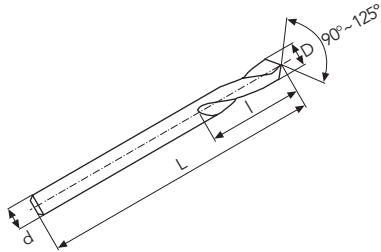

GRUPPI MATERIALE · MATERIAL GROUPS WERKSTOFFE GRUPPE · GROUPES MATIÈRE				1 ~ 22	1 ~ 22	1 ~ 22	1 ~ 22
CODICE / ITEM NO. / ARTIKEL NR. / RÉFÉRENCE				NCSD90	NCSDTC90	NCSD125	NCSDTC125
TIPO / TYPE / TYP / TYPE				NC	NC	NC	NC
MATERIALE / MATERIAL / WERKSTOFF / MATIÈRE				HSS/Co 8%	HSS/Co 8%	HSS/Co 8%	HSS/Co 8%
RIVESTIMENTO / COATING / BESCHICHTUNG / REVÊTEMENT				BR	TiCN	BR	TiCN
NORMA / NORM / NORM / NORME				YMW	YMW	YMW	YMW
ANGOLO / ANGLE / WINKEL / ANGLE				90°	90°	125°	125°
D(mm)	d	L	l	Stock	Stock	Stock	Stock
3	3	46	12	●	○	●	○
4	4	55	15	●	○	●	○
5	5	62	18	●	○	●	○
6	6	66	20	●	●	●	●
8	8	79	26	●	●	●	●
10	10	89	30	●	●	●	●
12	12	102	36	●	●	●	●
16	16	115	41	●	●	●	●
20	20	131	46	●	●	●	●
25	25	151	52	●	○	●	○

PUNTE A CENTRARE

CENTER DRILLS

ZENTRIERBOHRER

FORETS À CENTRER

60° A, R

DIN333

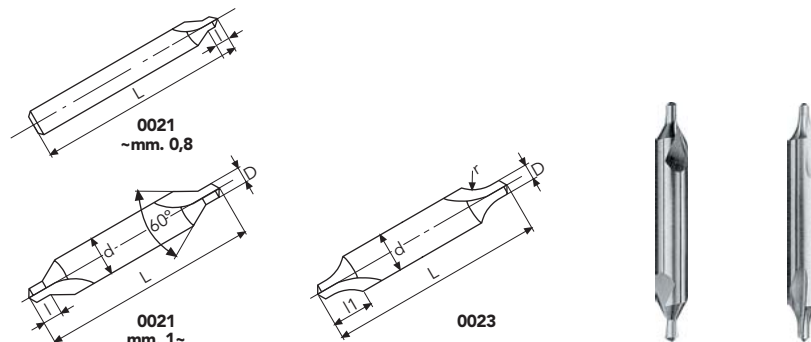

GRUPPI MATERIALE · MATERIAL GROUPS							4	5	6	12	4	5	6	12	
WERKSTOFFE GRUPPE · GROUPES MATIÈRE							13	14	15	13	14	15			
CODICE / ITEM NO. / ARTIKEL NR. / RÉFÉRENCE							0021				0023				
TIPO / TYPE / TYP / TYPE							A				R				
MATERIALE / MATERIAL / WERKSTOFF / MATIÈRE							HSS				HSS				
RIVESTIMENTO / COATING / BESCHICHTUNG / REVÊTEMENT							BR				BR				
NORMA / NORM / NORM / NORME							DIN333				DIN333				
ANGOLO / ANGLE / WINKEL / ANGLE							60°				RADIUS				
D(mm)	d	L	l	l1	rmax	rmin	Stock			Stock					
0.5	3.15	25	0.8				●			●					
0.8	3.15	25	1.1				●			●					
1	3.15	31.5	1.3	3	3.15	2.5	●			●					
1.25	3.15	31.5	1.6	3.35	4.	3.15	●			●					
1.6	4	4	2	4.25	5	4	●			●					
2	5	5	2.5	5.3	6.3	5	●			●					
2.5	6.3	6.3	3.1	6.7	8	6.3	●			●					
3.15	8	8	3.9	8.5	10	8	●			●					
4	10	10	5	10.6	12.5	10	●			●					
5	12.5	12.5	6.3	13.2	16	12.5	●			●					
6.3	16	16	8	17	20	16	●			●					
8	20	20	10.1	21.2	25	20	●			○					
10	25	25	12.8	26.5	31.5	25	●			○					

🇮🇹 PUNTE A CENTRARE 60°/90° - PER MATERIALI MEDIO DURI

🇬🇧 60°/90° CENTER DRILLS - FOR MEDIUM HARD MATERIALS

🇩🇪 60°/90° ZENTRIERBOHRER - FÜR HALBHARTWERKSTOFFE

🇫🇷 FORETS À CENTRER 60°/90° - POUR MATIÈRES MI-DURES

60°, 90° A
YMW NORM

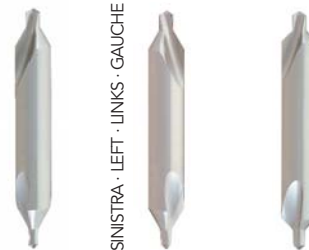
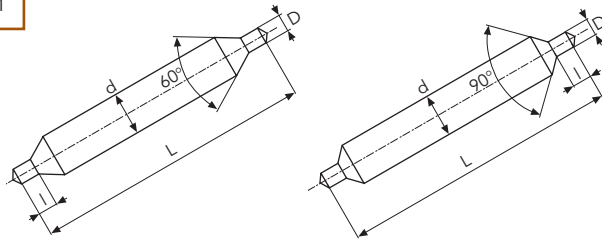

SINISTRA · LEFT · LINKS · GAUCHE

GRUPPI MATERIALE · MATERIAL GROUPS WERKSTOFFE GRUPPE · GROUPES MATIÈRE				4 5 6 12 13 14 15	4 5 6 12 13 14 15	4 5 6 12 13 14 15
CODICE / ITEM NO. / ARTIKEL NR. / RÉFÉRENCE				CD-S	CD-S-LH	CD-Q
TIPO / TYPE / TYP / TYPE				A	A	A
MATERIALE / MATERIAL / WERKSTOFF / MATIÈRE				HSS	HSS	HSS
RIVESTIMENTO / COATING / BESCHICHTUNG / REVÊTEMENT				BR	BR	BR
NORMA / NORM / NORM / NORME				YMW	YMW	YMW
ANGOLO / ANGLE / WINKEL / ANGLE				60°	60°	90°
D(mm)	d	L	l	Stock	Stock	Stock
0.5	3.5	35	0.5	○		
0.6	3.5	35	0.6	○		
0.7	3.5	35	0.7	○		
0.8	3.5	35	0.8	○		
1	4	35	1	○	●	○
1.2	5	40	1.2	○		
1.5	5	40	1.5	○	●	○
2	6	45	2	○	●	○
2.5	7.7	50	2.5	○	●	○
2.5	8	50	3.5	○		
3	7.7	55	3	○	●	○
3	8	55	3	○		
3	10	55	4	○		
4	10	65	4.5	○	●	○
4	12	66	5	○		
5	11	78	5.5	○	●	○
5	12	78	5.5	○		
5	14	78	6.5	○		
6	16	90	6.5	○	●	○
6	18	90	6.5	○	●	○

🇮🇹 PUNTE A CENTRARE 60° - PER MATERIALI MEDIO DURI - **SERIE LUNGA**

🇬🇧 60° CENTER DRILLS - FOR MEDIUM HARD MATERIALS - **LONG SERIES**

🇩🇪 60° ZENTRIERBOHRER - FÜR HALBHARTWERKSTOFFE - **LANG**

🇫🇷 FORETS À CENTRER 60° - POUR MATIÈRES MI-DURES - **LONGS**

60° A
YMW NORM

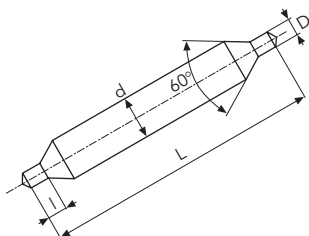

GRUPPI MATERIALE · MATERIAL GROUPS WERKSTOFFE GRUPPE · GROUPES MATIÈRE				4 5 6 12 13 14 15	4 5 6 12 13 14 15
CODICE / ITEM NO. / ARTIKEL NR. / RÉFÉRENCE				CD-SL	CD-SXL
TIPO / TYPE / TYP / TYPE				A	A
MATERIALE / MATERIAL / WERKSTOFF / MATIÈRE				HSS	HSS
RIVESTIMENTO / COATING / BESCHICHTUNG / REVÊTEMENT				BR	BR
NORMA / NORM / NORM / NORME				YMW	YMW
ANGOLO / ANGLE / WINKEL / ANGLE				60°	60*
D(mm)	d	L	l	Stock	Stock
1	4	100	1	●	
1	4	150	1		●
1.5	5	100	1.5	●	
1.5	5	150	1.5		●
2	6	100	2	●	
2	6	150	2		●
2.5	8	100	2.5	●	
2.5	8	150	2.5		●
3	8	100	3	●	
3	8	150	3		●
4	10	100	4.5	●	
4	10	150	4.5		●
5	12	100	5.5	●	
5	12	150	5.5		●

🇮🇹 PUNTE A CENTRARE 60° - METALLO DURO

🇬🇧 60° CENTER DRILLS - CARBIDE

🇩🇪 60° ZENTRIERBOHRER - HM

🇫🇷 FORETS À CENTRER 60° - CARBURE

60° A

YMW NORM

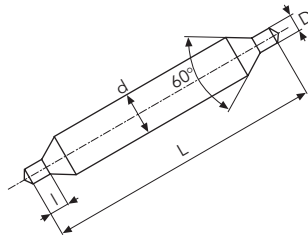

GRUPPI MATERIALE · MATERIAL GROUPS				5 6 12 13
WERKSTOFFE GRUPPE · GROUPES MATIÈRE				14 17 18 19
CODICE / ITEM NO. / ARTIKEL NR. / RÉFÉRENCE				C-CD-S
TIPO / TYPE / TYP / TYPE				A
MATERIALE / MATERIAL / WERKSTOFF / MATIÈRE				CARBIDE
RIVESTIMENTO / COATING / BESCHICHTUNG / REVÊTEMENT				BR
NORMA / NORM / NORM / NORME				YMW
ANGOLO / ANGLE / WINKEL / ANGLE				60°
D(mm)	d	L	l	Stock
1	4	35	1	○
1.5	5	40	1.5	○
2	6	45	2	○
2.5	7.7	50	2.5	○
3	7.7	55	3	○
4	10	65	4.5	○
5	11	78	5.5	○

- PUNTE A CENTRARE 60° - PER MATERIALI TENERI
- 60° CENTER DRILLS - FOR SOFT MATERIALS
- 60° ZENTRIERBOHRER - FÜR WEICHE WERKSTOFFE
- FORETS À CENTRER 60° - POUR MATIÈRES TENDRES

60° A

YMW NORM

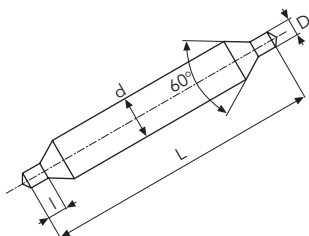

GRUPPI MATERIALE · MATERIAL GROUPS WERKSTOFFE GRUPPE · GROUPES MATIÈRE				1 2 3 4 8 9 10 16 17 18	1 2 3 4 8 9 10 16 17 18
CODICE / ITEM NO. / ARTIKEL NR. / RÉFÉRENCE				CE-S	CE-S-TI
TIPO / TYPE / TYP / TYPE				A	A
MATERIALE / MATERIAL / WERKSTOFF / MATIÈRE				HSS	HSS
RIVESTIMENTO / COATING / BESCHICHTUNG / REVÊTEMENT				BR	TiN
NORMA / NORM / NORM / NORME				YMW	YMW
ANGOLO / ANGLE / WINKEL / ANGLE				60°	60°
D(mm)	d	L	l	Stock	Stock
0.5	3.5	35	0.5	○	
0.6	3.5	35	0.6	○	
0.7	3.5	35	0.7	○	
0.8	3.5	35	0.8	○	
0.9	4	35	0.9	○	
1	4	35	1	○	○
1.2	5	40	1.2	○	
1.5	5	40	1.5	○	○
2	6	45	2	○	○
2.5	7.7	50	2.5	○	○
2.5	8	50	3.5	○	
3	7.7	55	3	○	○
3	8	55	3	○	
3	10	55	4	○	
4	10	65	4.5	○	○
4	12	66	5	○	
5	11	78	5.5	○	○
5	12	78	5.5	○	
5	14	78	6.5	○	
6	16	90	6.5	○	
6	18	90	6.5	○	○
8	18	100	8	○	
10	18	100	10	○	
12	25	120	12	○	

🇮🇹 PUNTE A CENTRARE 60° - PER MATERIALI TENERI - SERIE LUNGA

🇬🇧 60° CENTER DRILLS - FOR SOFT MATERIALS - LONG SERIES

🇩🇪 60° ZENTRIERBOHRER - FÜR WEICHE WERKSTOFFE - LANG

🇫🇷 FORETS À CENTRER 60° - POUR MATIÈRES TENDRES - LONGS

60° A

YMW NORM

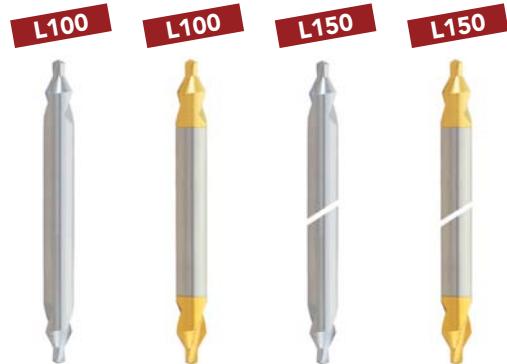
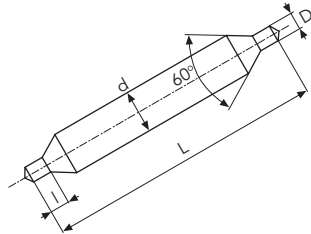

GRUPPI MATERIALE · MATERIAL GROUPS WERKSTOFFE GRUPPE · GROUPES MATIÈRE				1 2 3 4 8 9 10 16 17 18	1 2 3 4 8 9 10 16 17 18	1 2 3 4 8 9 10 16 17 18	1 2 3 4 8 9 10 16 17 18
CODICE / ITEM NO. / ARTIKEL NR. / RÉFÉRENCE				CE-SL	CE-SL-TI	CE-SXL	CE-SXL-TI
TIPO / TYPE / TYP / TYPE				A	A	A	A
MATERIALE / MATERIAL / WERKSTOFF / MATIÈRE				HSS	HSS	HSS	HSS
RIVESTIMENTO / COATING / BESCHICHTUNG / REVÊTEMENT				BR	TiN	BR	TiN
NORMA / NORM / NORM / NORME				YMW	YMW	YMW	YMW
ANGOLO / ANGLE / WINKEL / ANGLE				60°	60*	60*	60*
D(mm)	d	L	l	Stock	Stock	Stock	Stock
1	4	100	1	○	○		
1	4	150	1			○	○
1.5	5	100	1.5	○	○		
1.5	5	150	1.5			○	○
2	6	100	2	○	○		
2	6	150	2			○	○
2.5	8	100	2.5	○	○		
2.5	8	150	2.5			○	○
3	8	100	3	○	○		
3	8	150	3			○	○
4	10	100	4.5	○	○		
4	10	150	4.5			○	○
5	12	100	5.5	○	○		
5	12	150	5.5			○	○

- PUNTE A CENTRARE 90° - PER MATERIALI TENERI**
- 90° CENTER DRILLS - FOR SOFT MATERIALS**
- 90° ZENTRIERBOHRER - FÜR WEICHE WERKSTOFFE**
- FORETS À CENTRER 90° - POUR MATIÈRES TENDRES**

90° A

YMW NORM

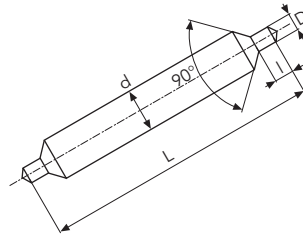

GRUPPI MATERIALE · MATERIAL GROUPS				1	2	3	4	8	1	2	3	4	8
WERKSTOFFE GRUPPE · GROUPES MATIÈRE				9	10	16	17	18	9	10	16	17	18
CODICE / ITEM NO. / ARTIKEL NR. / RÉFÉRENCE				CE-Q					CE-Q-TI				
TIPO / TYPE / TYP / TYPE				A					A				
MATERIALE / MATERIAL / WERKSTOFF / MATIÈRE				HSS					HSS				
RIVESTIMENTO / COATING / BESCHICHTUNG / REVÊTEMENT				BR					TiN				
NORMA / NORM / NORM / NORME				YMW					YMW				
ANGOLO / ANGLE / WINKEL / ANGLE				90°					90°				
D(mm)	d	L	l	Stock					Stock				
1	4	35	1	○					○				
1.5	5	40	1.5	○					○				
2	6	45	2	○					○				
2.5	7.7	50	2.5	○					○				
3	7.7	55	3	○					○				
4	10	65	4.5	○					○				
5	11	78	5.5	○					○				
6	16	90	6.5	○					○				
6	18	90	6.5	○					○				

🇮🇹 PUNTE A CENTRARE 90° - PER MATERIALI TENERI - SERIE LUNGA

🇬🇧 90° CENTER DRILLS - FOR SOFT MATERIALS - LONG SERIES

🇩🇪 90° ZENTRIERBOHRER - FÜR WEICHE WERKSTOFFE - LANG

🇫🇷 FORETS À CENTRER 90° - POUR MATIÈRES TENDRES - LONGS

90° A
YMW NORM

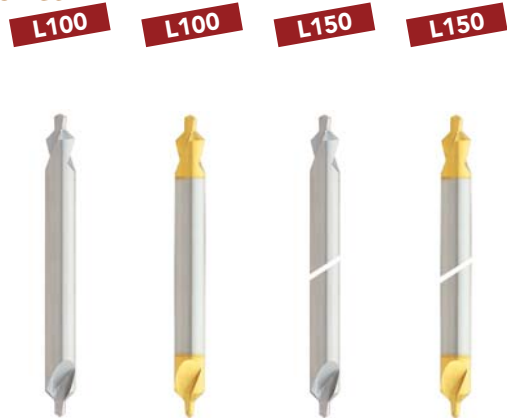
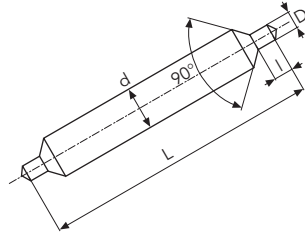

GRUPPI MATERIALE · MATERIAL GROUPS WERKSTOFFE GRUPPE · GROUPES MATIÈRE				1 2 3 4 8 9 10 16 17 18	1 2 3 4 8 9 10 16 17 18	1 2 3 4 8 9 10 16 17 18	1 2 3 4 8 9 10 16 17 18
CODICE / ITEM NO. / ARTIKEL NR. / RÉFÉRENCE				CE-QL	CE-QL-TI	CE-QXL	CE-QXL-TI
TIPO / TYPE / TYP / TYPE				A	A	A	A
MATERIALE / MATERIAL / WERKSTOFF / MATIÈRE				HSS	HSS	HSS	HSS
RIVESTIMENTO / COATING / BESCHICHTUNG / REVÊTEMENT				BR	TiN	BR	TiN
NORMA / NORM / NORM / NORME				YMW	YMW	YMW	YMW
ANGOLO / ANGLE / WINKEL / ANGLE				90°	90°	90°	90°
D(mm)	d	L	l	Stock	Stock	Stock	Stock
1	4	100	1	○	○		
1	4	150	1			○	○
1.5	5	100	1.5	○	○		
1.5	5	150	1.5			○	○
2	6	100	2	○	○		
2	6	150	2			○	○
2.5	8	100	2.5	○	○		
2.5	8	150	2.5			○	○
3	8	100	3	○	○		
3	8	150	3			○	○
4	10	100	4.5	○	○		
4	10	150	4.5			○	○
5	12	100	5.5	○	○		
5	12	150	5.5			○	○