

| CODICE · ITEM NO. ARTIKEL NR. · RÉFÉRENCE | DESCRIZIONE · DESCRIPTION EZEICHUNG · DESCRIPTION | PAGINA · PAGE SEITE · PAGE | |
|--|--|-------------------------------|---|
| 7130 | M - ISO529 PO HSSE | 236 |  |
| 7530 | M - ISO529 PO HSSE | 237 |  |
| 7130NX | M - ISO529 PO HSSE NX | 236 |  |
| 7530NX | M - ISO529 PO HSSE NX | 237 |  |
| 7140 | M - ISO529 SP40° HSSE | 236 |  |
| 7540 | M - ISO529 SP40° HSSE | 237 |  |
| 7140X | M - ISO529 SP40° HSSE OX | 236 |  |
| 7540X | M - ISO529 SP40° HSSE OX | 237 |  |
| 8120 A-D-C | M - ISO529 STR HSS | 236 |  |
| 8520 A-D-C | M - ISO529 STR HSS | 237 |  |
| 7230 | MF - ISO529 PO HSSE | 238 |  |
| 7630 | MF - ISO529 PO HSSE | 239 |  |
| 7240X | MF - ISO529 SP40° HSSE OX | 238 |  |
| 7640X | MF - ISO529 SP40° HSSE OX | 239 |  |
| 8220 D-C | MF - ISO529 STR HSS | 238 |  |
| 8620 D-C | MF - ISO529 STR HSS | 239 |  |

🇮🇹 MASCHI A MACCHINA PER FORI CIECHI E PASSANTI

🇬🇧 BLIND AND THROUGH HOLES MACHINE TAPS

🇩🇪 MASCHINENGEWINDEBOHRER FÜR DURCHGANGS-UND GRUNDLÖCHER

🇫🇷 TARAUDS MACHINE POUR TROUS BORGNES ET DÉBOUCHANTS

M
ISO529

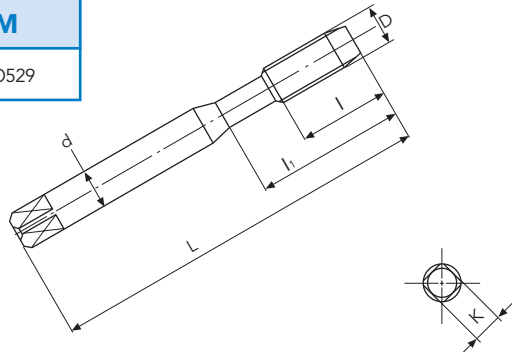

| GRUPPI MATERIALE · MATERIAL GROUPS WERKSTOFFE GRUPPE · GROUPES MATIÈRE | | 1 2 3 4 16 17 | 1 2 3 4 16 17 | 1 2 3 4 14 16 17 18 19 | 1 2 3 4 14 16 17 18 19 | 1 2 3 4 12 13 14 17 | | | | | | | |
|---|------|------------------|------------------|---------------------------|---------------------------|------------------------|------|------|-------|-------|-------|-------|-------|
| CODICE / ITEM NO. / ARTIKEL NR. / RÉFÉRENCE | | 7130 | 7130NX | 7140 | 7140X | 8120 | | | | | | | |
| TIPO / TYPE / TYP / TYPE | | PO | PO | SP40° | SP40° | STR | | | | | | | |
| MATERIALE / MATERIAL / WERKSTOFF / MATIÈRE | | HSSE | HSSE | HSSE | HSSE | HSS | | | | | | | |
| RIVESTIMENTO / COATING / BESCHICHTUNG / REVÊTEMENT | | BR | NX | BR | OX | BR | | | | | | | |
| NORMA / NORM / NORM / NORME | | ISO529 | ISO529 | ISO529 | ISO529 | ISO529 | | | | | | | |
| TOLLERANZA / TOLERANCE / TOLERANZ / TOLÉRANCE | | ISO2(6H) | ISO2(6H) | ISO2(6H) | ISO2(6H) | ISO2(6H) | | | | | | | |
| IMBOCCO / CHAMFER / ANSCHNITT / ENTRÉE | | B(3.5P~5P) | B(3.5P~5P) | C(2P~3P) | C(2P~3P) | A-D-C | | | | | | | |
| D | p | Ø | L | * | I-SP | l1 | d | k | Stock | Stock | Stock | Stock | Stock |
| M 2 | 0.4 | 1.6 | 41 | 8 | 8 | 2.5 | 2 | | ● | ○ | ○ | ● | ● |
| M 2.5 | 0.45 | 2.1 | 44.5 | 9.5 | 9.5 | 2.8 | 2.24 | | ● | ○ | ○ | ● | ● |
| M 3 | 0.5 | 2.5 | 48 | 11 | 5 | 18 | 3.15 | 2.5 | ● | ○ | ○ | ● | ● |
| M 3.5 | 0.6 | 2.9 | 50 | 13 | 7 | 20 | 3.55 | 2.8 | △ | △ | △ | △ | △ |
| M 4 | 0.7 | 3.3 | 53 | 13 | 7 | 21 | 4 | 3.15 | ● | ○ | ○ | ● | ● |
| M 5 | 0.8 | 4.2 | 58 | 16 | 9 | 25 | 5 | 4 | ● | ○ | ○ | ● | ● |
| M 6 | 1 | 5 | 66 | 19 | 11 | 30 | 6.3 | 5 | ● | ○ | ○ | ● | ● |
| M 8 | 1.25 | 6.8 | 72 | 22 | 12 | 35 | 8 | 6.3 | ● | ○ | ○ | ● | ● |
| M10 | 1.5 | 8.5 | 80 | 24 | 13 | 39 | 10 | 8 | ● | ○ | ○ | ● | ● |

*I-STR, PO



| | | | | | |
|--------------------|---|---|---|---|---|
| M 2 ~ M 2.5 | 2 | 2 | 2 | 2 | 3 |
| M 3 ~ M 6 | 3 | 3 | 3 | 3 | 3 |
| M 8 ~ M10 | 3 | 3 | 3 | 3 | 4 |

MASCHI A MACCHINA PER FORI CIECHI E PASSANTI

BLIND AND THROUGH HOLES MACHINE TAPS

MASCHINENGEWINDEBOHRER FÜR DURCHGANGS-UND GRUNDLÖCHER

TARAUDS MACHINE POUR TROUS BORGNES ET DÉBOUCHANTS

M
ISO529

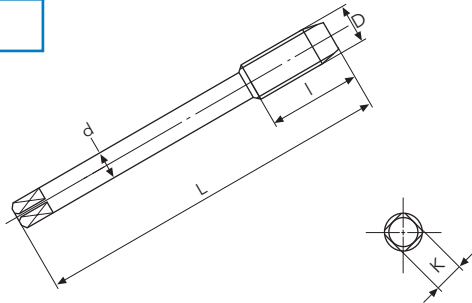

| GRUPPI MATERIALE · MATERIAL GROUPS WERKSTOFFE GRUPPE · GROUPES MATIÈRE | | | | | | | | 1 2 3 4 16 17 | 1 2 3 4 16 17 | 1 2 3 4 14 16 17 18 19 | 1 2 3 4 14 16 17 18 19 | 1 2 3 4 12 13 14 17 |
|---|------|------|-----|----|------|------|------|------------------|------------------|---------------------------|---------------------------|------------------------|
| CODICE / ITEM NO. / ARTIKEL NR. / RÉFÉRENCE | | | | | | | | 7530 | 7530NX | 7540 | 7540X | 8520 |
| TIPO / TYPE / TYP / TYPE | | | | | | | | PO | PO | SP40° | SP40° | STR |
| MATERIALE / MATERIAL / WERKSTOFF / MATIÈRE | | | | | | | | HSSE | HSSE | HSSE | HSSE | HSS |
| RIVESTIMENTO / COATING / BESCHICHTUNG / REVÊTEMENT | | | | | | | | BR | NX | BR | OX | BR |
| NORMA / NORM / NORM / NORME | | | | | | | | ISO529 | ISO529 | ISO529 | ISO529 | ISO529 |
| TOLLERANZA / TOLERANCE / TOLERANZ / TOLÉRANCE | | | | | | | | ISO2(6H) | ISO2(6H) | ISO2(6H) | ISO2(6H) | ISO2(6H) |
| IMBOCCO / CHAMFER / ANSCHNITT / ENTRÉE | | | | | | | | B(3.5P~5P) | B(3.5P~5P) | C(2P~3P) | C(2P~3P) | A-D-C |
| D | p | Ø | L | * | I-SP | d | k | Stock | Stock | Stock | Stock | Stock |
| M 3 | 0.5 | 2.5 | 48 | 11 | 5 | 2.24 | 1.8 | △ | | | △ | △ |
| M 4 | 0.7 | 3.3 | 53 | 13 | 7 | 3.15 | 2.5 | △ | | | △ | △ |
| M 5 | 0.8 | 4.2 | 58 | 16 | 9 | 4 | 3.15 | △ | | | △ | △ |
| M 6 | 1 | 5 | 66 | 19 | 11 | 4.5 | 3.55 | △ | | | △ | △ |
| M 8 | 1.25 | 6.8 | 72 | 22 | 12 | 6.3 | 5 | △ | | | △ | △ |
| M10 | 1.5 | 8.5 | 80 | 24 | 13 | 8 | 6.3 | △ | | | △ | △ |
| M12 | 1.75 | 10.3 | 89 | 29 | 15 | 9 | 7.1 | ● | ○ | ○ | ● | ● |
| M14 | 2 | 12 | 95 | 30 | 18 | 11.2 | 9 | ● | ○ | ○ | ● | ● |
| M16 | 2 | 14 | 102 | 32 | 18 | 12.5 | 10 | ● | ○ | ○ | ● | ● |
| M18 | 2.5 | 15.5 | 112 | 37 | 20 | 14 | 11.2 | ● | ○ | ○ | ● | ● |
| M20 | 2.5 | 17.5 | 112 | 37 | 20 | 14 | 11.2 | ● | ○ | ○ | ● | ● |
| M22 | 2.5 | 19.5 | 118 | 38 | 20 | 16 | 12.5 | ○ | ○ | ○ | ○ | ○ |
| M24 | 3 | 21 | 130 | 45 | 25 | 18 | 14 | ○ | ○ | ○ | ● | ○ |
| M27 | 3 | 24 | 135 | 45 | 25 | 20 | 16 | ○ | ○ | ○ | ○ | ○ |
| M30 | 3.5 | 26.5 | 138 | 48 | 30 | 20 | 16 | ○ | ○ | ○ | ○ | ○ |

*I-STR, PO



| | | | | | |
|------------------|---|---|---|---|---|
| M 3 ~ M 6 | 3 | 3 | 3 | 3 | 3 |
| M 8 ~ M16 | 3 | 3 | 3 | 3 | 4 |
| M18 ~ M24 | 3 | 3 | 4 | 4 | 4 |
| M27 ~ M30 | 4 | 4 | 4 | 4 | 4 |

MASCHI A MACCHINA PER FORI CIECHI E PASSANTI

BLIND AND THROUGH HOLES MACHINE TAPS

MASCHINENGEWINDEBOHRER FÜR DURCHGANGS-UND GRUNDLÖCHER

TARAUDS MACHINE POUR TROUS BORGNES ET DÉBOUCHANTS

MF
ISO529

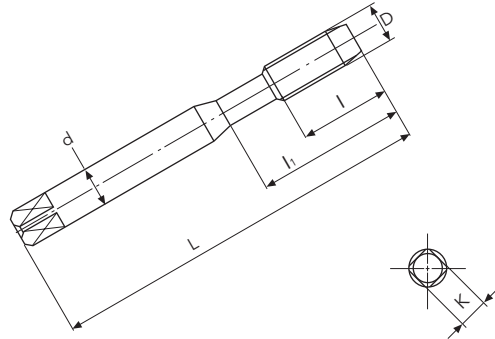

| GRUPPI MATERIALE · MATERIAL GROUPS WERKSTOFFE GRUPPE · GROUPES MATIÈRE | | 1 2 3 4 16 17 | 1 2 3 4 14 16 17 18 19 | 1 2 3 4 12 13 14 17 | | | | | | | |
|---|------|------------------|---------------------------|------------------------|------|----|------|------|-------|-------|-------|
| CODICE / ITEM NO. / ARTIKEL NR. / RÉFÉRENCE | | 7230 | 7240X | 8220 | | | | | | | |
| TIPO / TYPE / TYP / TYPE | | PO | SP40° | STR | | | | | | | |
| MATERIALE / MATERIAL / WERKSTOFF / MATIÈRE | | HSSE | HSSE | HSS | | | | | | | |
| RIVESTIMENTO / COATING / BESCHICHTUNG / REVÊTEMENT | | BR | OX | BR | | | | | | | |
| NORMA / NORM / NORM / NORME | | ISO529 | ISO529 | ISO529 | | | | | | | |
| TOLLERANZA / TOLERANCE / TOLERANZ / TOLÉRANCE | | ISO2(6H) | ISO2(6H) | ISO2(6H) | | | | | | | |
| IMBOCCO / CHAMFER / ANSCHNITT / ENTRÉE | | B(3.5P~5P) | C(2P~3P) | D-C | | | | | | | |
| D | p | ∅ | L | * | I-SP | l1 | d | k | Stock | Stock | Stock |
| M 3 | 0.35 | 2.7 | 48 | 11 | 5 | 18 | 3.15 | 2.5 | △ | △ | △ |
| M 4 | 0.5 | 3.5 | 53 | 13 | 5 | 21 | 4 | 3.15 | △ | △ | △ |
| M 5 | 0.5 | 4.5 | 58 | 16 | 6 | 25 | 5 | 4 | △ | △ | △ |
| M 6 | 0.75 | 5.3 | 66 | 19 | 8 | 30 | 6.3 | 5 | △ | △ | △ |
| M 8 | 1 | 7 | 69 | 19 | 12 | 35 | 8 | 6.3 | △ | △ | △ |
| M10 | 1.25 | 8.8 | 76 | 20 | 12 | 39 | 10 | 8 | △ | △ | △ |
| M10 | 1 | 9 | 76 | 20 | 12 | 39 | 10 | 8 | △ | △ | △ |

*I-STR, PO



| | | | |
|--------------------|---|---|---|
| M 2 ~ M 2.5 | 2 | 2 | 3 |
| M 3 ~ M 6 | 3 | 3 | 3 |
| M 8 ~ M10 | 3 | 3 | 4 |

- MASCHI A MACCHINA PER FORI CIECHI E PASSANTI**
- BLIND AND THROUGH HOLES MACHINE TAPS**
- MASCHINENGEWINDEBOHRER FÜR DURCHGANGS-UND GRUNDLÖCHER**
- TARAUDS MACHINE POUR TROUS BORGNES ET DÉBOUCHANTS**

MF

ISO529

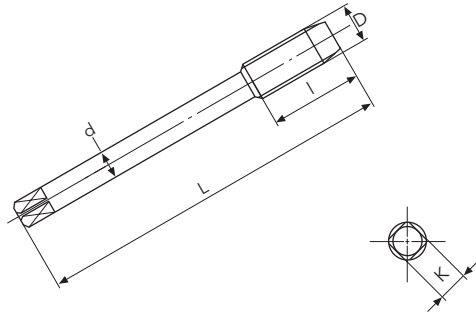

| GRUPPI MATERIALE · MATERIAL GROUPS WERKSTOFFE GRUPPE · GROUPES MATIÈRE | | | | | | | | 1 2 3 4 16 17 | 1 2 3 4 14 16 17 18 19 | 1 2 3 4 12 13 14 17 |
|---|------|------|-----|----|------|------|------|------------------|---------------------------|------------------------|
| CODICE / ITEM NO. / ARTIKEL NR. / RÉFÉRENCE | | | | | | | | 7630 | 7640X | 8620 |
| TIPO / TYPE / TYP / TYPE | | | | | | | | PO | SP40° | STR |
| MATERIALE / MATERIAL / WERKSTOFF / MATIÈRE | | | | | | | | HSSE | HSSE | HSS |
| RIVESTIMENTO / COATING / BESCHICHTUNG / REVÊTEMENT | | | | | | | | BR | OX | BR |
| NORMA / NORM / NORM / NORME | | | | | | | | ISO529 | ISO529 | ISO529 |
| TOLLERANZA / TOLERANCE / TOLERANZ / TOLÉRANCE | | | | | | | | ISO2(6H) | ISO2(6H) | ISO2(6H) |
| IMBOCCO / CHAMFER / ANSCHNITT / ENTRÉE | | | | | | | | B(3.5P~5P) | C(2P~3P) | D-C |
| D | p | Ø | L | * | I-SP | d | k | Stock | Stock | Stock |
| M 8 | 1 | 7 | 69 | 19 | 12 | 6.3 | 5 | △ | △ | △ |
| M10 | 1.25 | 8.8 | 76 | 20 | 12 | 8 | 6.3 | △ | △ | △ |
| M10 | 1 | 9 | 76 | 20 | 12 | 8 | 6.3 | △ | △ | △ |
| M12 | 1.5 | 10.5 | 89 | 29 | 14 | 9 | 7.1 | △ | △ | △ |
| M12 | 1.25 | 10.8 | 84 | 24 | 14 | 9 | 7.1 | △ | △ | △ |
| M14 | 1.5 | 12.5 | 95 | 30 | 14 | 11.2 | 9 | △ | △ | △ |
| M14 | 1.25 | 12.8 | 90 | 25 | 14 | 11.2 | 9 | △ | △ | △ |
| M16 | 1.5 | 14.5 | 102 | 32 | 14 | 12.5 | 10 | △ | △ | △ |
| M18 | 1.5 | 16.5 | 104 | 29 | 14 | 14 | 11.2 | △ | △ | △ |
| M20 | 1.5 | 18.5 | 104 | 29 | 14 | 14 | 11.2 | △ | △ | △ |
| M22 | 1.5 | 20.5 | 113 | 33 | 14 | 16 | 12.5 | △ | △ | △ |
| M24 | 2 | 22 | 120 | 35 | 18 | 18 | 14 | △ | △ | △ |
| M24 | 1.5 | 22.5 | 120 | 35 | 18 | 18 | 14 | △ | △ | △ |
| M25 | 1.5 | 23.5 | 120 | 35 | 18 | 18 | 14 | △ | △ | △ |
| M27 | 2 | 25 | 127 | 37 | 18 | 20 | 16 | △ | △ | △ |
| M27 | 1.5 | 25.5 | 127 | 37 | 18 | 20 | 16 | △ | △ | △ |
| M28 | 2 | 26 | 127 | 37 | 18 | 20 | 16 | △ | △ | △ |
| M30 | 2 | 28 | 127 | 37 | 18 | 20 | 16 | △ | △ | △ |
| M30 | 1.5 | 28.5 | 127 | 37 | 18 | 20 | 16 | △ | △ | △ |

*I-STR, PO



| | | | |
|------------------|---|---|---|
| M 8 ~ M16 | 3 | 3 | 4 |
| M18 ~ M24 | 3 | 4 | 4 |
| M27 ~ M30 | 4 | 4 | 4 |