



<b>CODICE · ITEM NO.</b> <b>ARTIKEL NR. · RÉFÉRENCE</b>	<b>DESCRIZIONE · DESCRIPTION</b> <b>EZEICHUNG · DESCRIPTION</b>	<b>PAGINA · PAGE</b> <b>SEITE · PAGE</b>	
F-SL	M - LHSP15° HSSE TIN	68	
F-SP	M - SP45° HSSE TIN	68	

MASCHI SINCRO - FAST - HSSE

FAST - SYNCHRO TAPS - HSSE

FAST - SYNCHRO GEWINDEBOHRER - HSSE

TARAUDS SYNCHRO - FAST - HSSE

<b>M, MF</b>
JIS

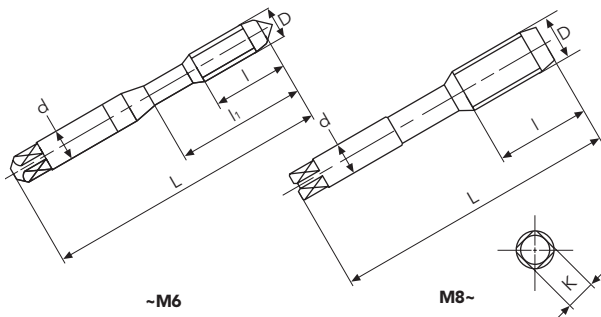

GRUPPI MATERIALE · MATERIAL GROUPS		1	2	3	1	2	3			
WERKSTOFFE GRUPPE · GROUPES MATIÈRE		16	17		16	17				
CODICE / ITEM NO. / ARTIKEL NR. / RÉFÉRENCE		F-SL			F-SP					
TIPO / TYPE / TYP / TYPE		LHSP 15°			SP45°					
MATERIALE / MATERIAL / WERKSTOFF / MATIÈRE		HSSE			HSSE					
RIVESTIMENTO / COATING / BESCHICHTUNG / REVÊTEMENT		TiN			TiN					
NORMA / NORM / NORM / NORME		JIS			JIS					
TOLLERANZA / TOLERANCE / TOLERANZ / TOLÉRANCE		P CLASS*			P CLASS*					
IMBOCCO / CHAMFER / ANSCHNITT / ENTRÉE		5P			2.5P					
D	p	Ø	L	LOSP	SP	l1	d	k	Stock	Stock
M 3	0.5	2.5	46	11	5	18	4	3.2	● (P2)	● (P2)
M 4	0.7	3.3	52	13	7	21	5	4	● (P2)	● (P2)
M 5	0.8	4.2	60	16	9	25	5.5	4.5	● (P2)	● (P2)
M 6	1	5.0	62	19	11	30	6	4.5	● (P2)	● (P2)
M 8	1.25	6.8	70	22	12		6.2	5	● (P3)	● (P3)
M10	1.5	8.5	75	24	13		7	5.5	● (P3)	● (P3)
M12	1.75	10.3	82	29	15		8.5	6.5	● (P4)	● (P4)
MF10	1.25	8.8	75	32	12		7	5.5	○ (P3)	○ (P3)
MF12	1.5	10.5	82	32	14		8.5	6.5	○ (P3)	○ (P3)
MF12	1.25	10.8	82	32	14		8.5	6.5	○ (P4)	○ (P4)

\*P CLASS page 47



M 3 ~ M12	3	3
-----------	---	---